

# HRCPII Slider Assembly

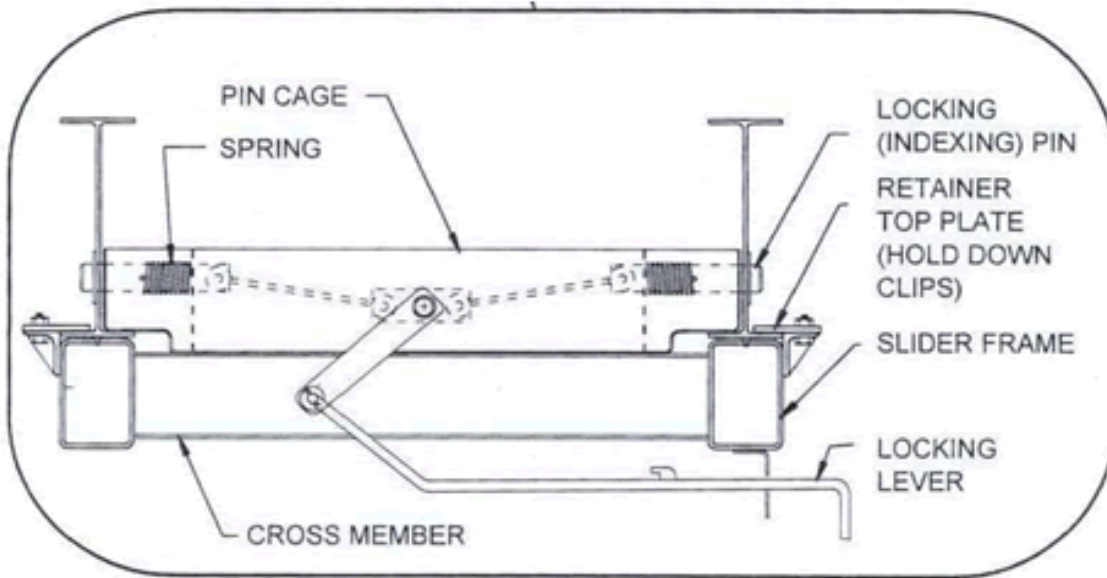
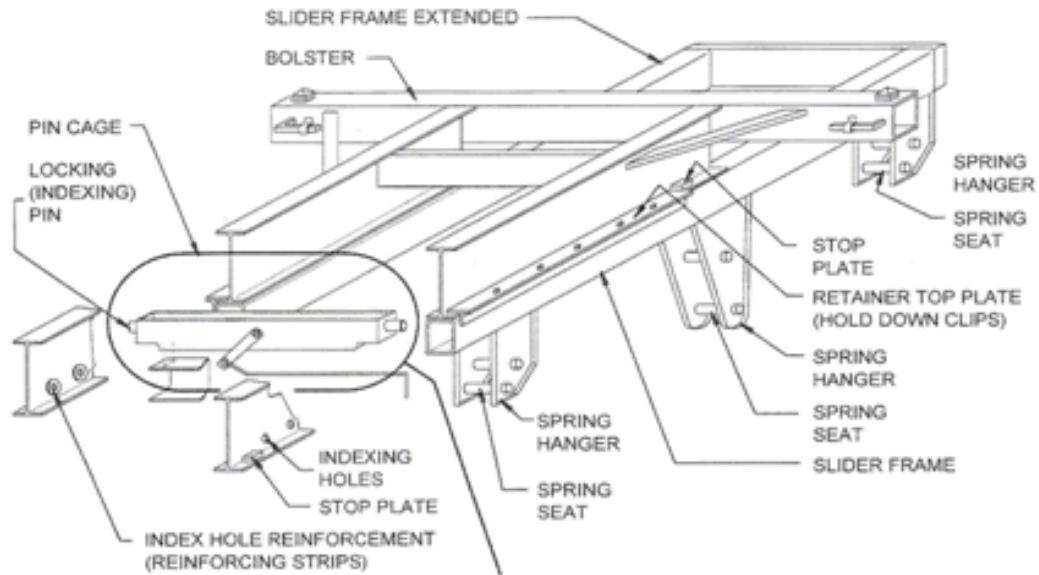

# Slider Inspection Procedure

1. Sliders must be properly locked before a chassis is moved.
2. Sliders that are not properly maintained and locked can cause the entire suspension and axle assembly to become separated from the chassis.
3. Sliders should be inspected each time before a chassis is moved.
4. All slider chassis use the same method of aligning the holes between the chassis mainframe and the running gear. When the holes are properly aligned, the locking pins protrude the holes of the slider and locks the slider assembly in the desired position.
5. Stop plates are *never* used to stop the chassis from separating.
6. The locking pins should penetrate the index holes at least  $\frac{1}{4}$  inch.
7. Pull and release the slider mechanism a couple of times to ensure it works properly.
8. If the pins do not engage, do not move the chassis. Have an M&R vendor determine if chassis needs further repair. **Do Not Attempt to Move to Repair Area.**